

Installation Manual

Please keep this page for your online registration.

No. FIRDRDA06V1.0





CAUTION

1. Follow installation instructions carefully to ensure unit is properly attached to the wall.
2. To avoid a possible fire hazard, it is essential unit is mounted in accordance with guidelines stated in the instruction.
3. Radiator is intended for indoor use only, do not place radiator inside a shower, steam room, or wherever unit would be exposed to water.

TECHNICAL DATA

It should only be filled with water, and at a temperature below 100°C (212°F). See table below for installation requirements. If the temperature exceeds 48°C (or 120°F), please install a warning sign near the product to avoid burning and scolding accidents.

Temperature: $0^{\circ}\text{C} < t \leq 100^{\circ}\text{C}$

Comments: If ambient temperature drops below 1°C, drain out the water to prevent freezing.

Important

Wipe the surface clean with a soft, damp cloth. Never use abrasive cleaners on this product as they will damage the surface.

TOOLS YOU MIGHT NEED

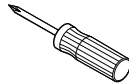

Screwdriver



Pencil



Adjustable Wrench



Rubber Hammer



Glove



Tape Measure



Spirit Level

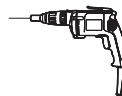

Electric Drill



Clean Cloth

IMPORTANT CHILD SAFETY NOTE

Important: Please note that you are 100% legally responsible for your own child's safety at home. Once the radiator is installed, it can become a hazard for children as a) This radiator is not designed to support unreasonable extra weight, such as that of a child, and b) The radiator becomes hot during use. Due to this, we must stress that you should not allow children to climb/grab/play with the radiator or rails, as this can cause accident or injury for the child, from heat, falling, or the radiator being pulled off the wall.

BEFORE INSTALLATION

- Observe all local plumbing and building codes.
- Shut off the main water supply.
- Read these instructions carefully to ensure proper installation.
- Check to make sure you have the following parts indicated below.



CAUTION

Please check you have all of these items in the box.

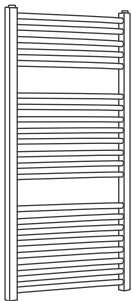
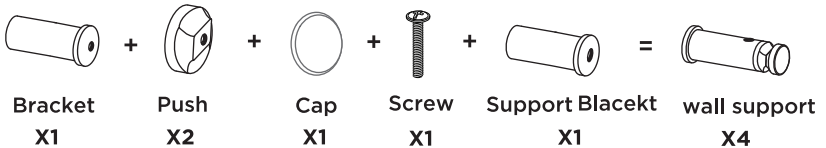

Body X1



Adjustment base X4



Washer X2



Masonry Wall Plug X4



Small Screw X4



Long Screw X4



Airvent X1



Blanking plug X1

REQUIRED PARTS

Option1: Thermostatic heating element(1pcs)+ Blanking plug(1pcs)+ Thermostatic controller(1pcs)

Option2: Heating element(1pcs)+ Blanking plug(1pcs)

Option3: Valve(2pcs)

INSTALLATION PROCEDURE

1

Put the towel rail parallel onto the wall, 60cm above the ground or so, pinpoint the 4 positions for the bracket, mark them with a pencil.



Make sure the towel rail is installed vertically.



Before installation place a dust sheet on the floor to prevent losing any small parts.

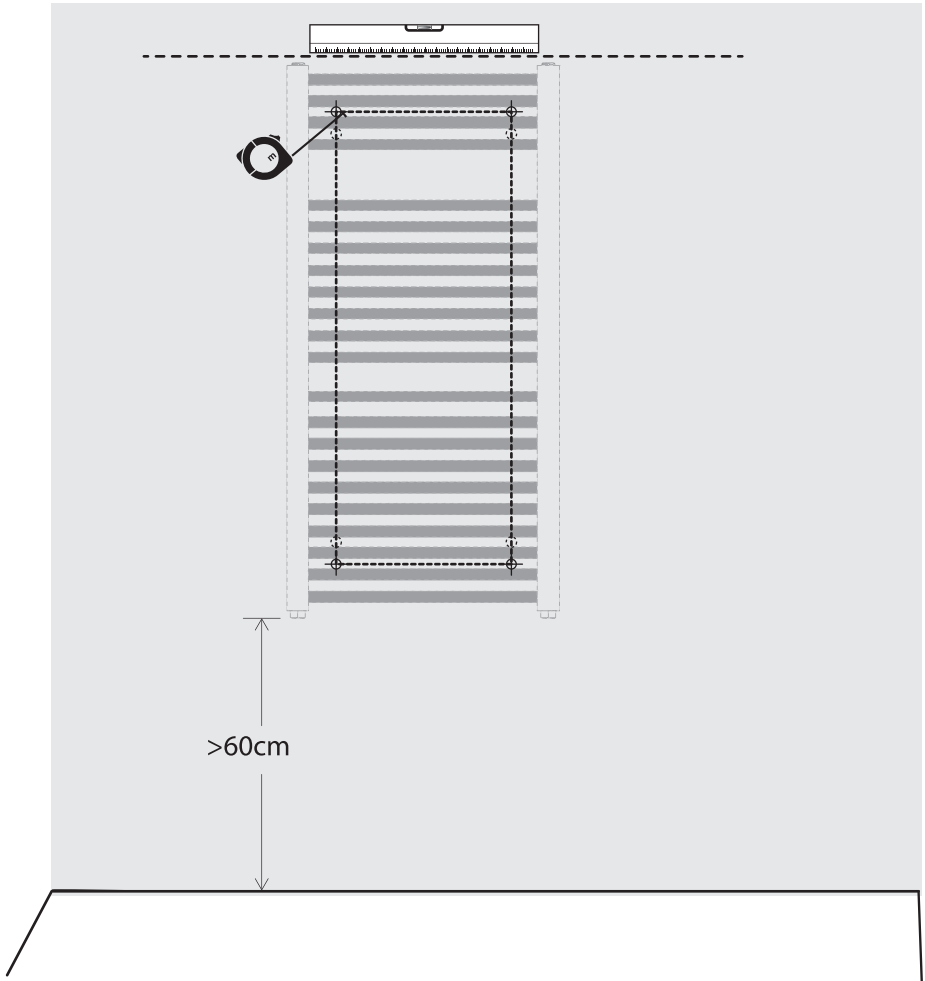

INSTALLATION PROCEDURE

2

Drill 4 holes of 8mm diameter, with the same depth of the masonry wall plug, put the masonry wall plug into the hole.

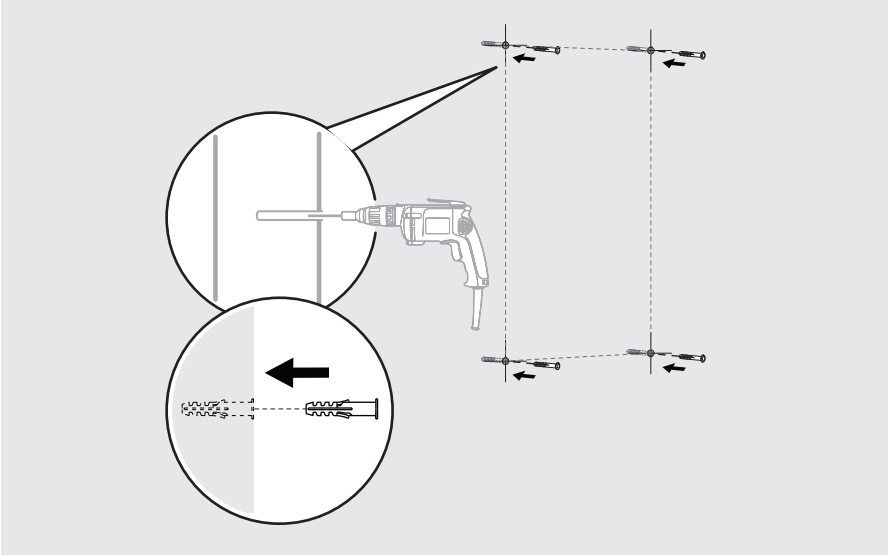

3

Take out the bracket parts, put the wall support on the hold place, with screw, using screw driver to fix the wall support on the wall. The flat radiator have no adjustment bases.

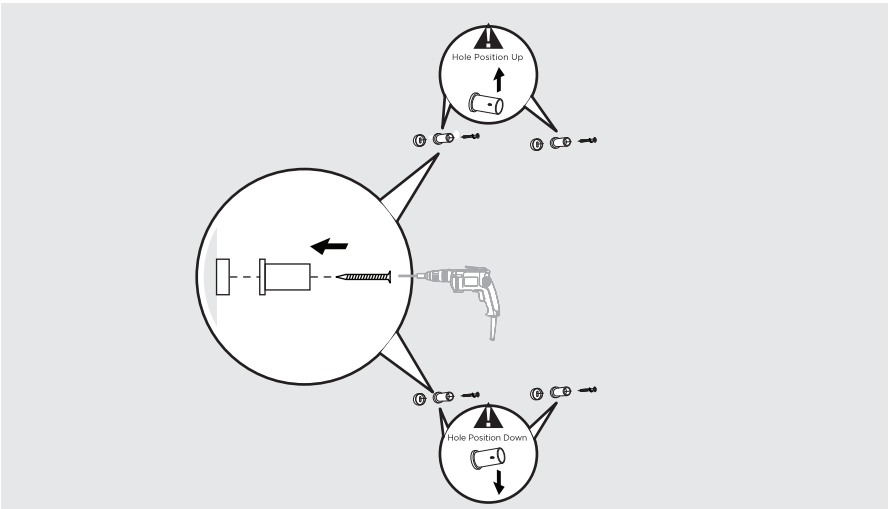

INSTALLATION PROCEDURE

4

Please remove 4 plastic insert on the radiator, then screw the blanking plug and air vent into the top two threads in the upright channels of the radiator. Apply PTFT tap.

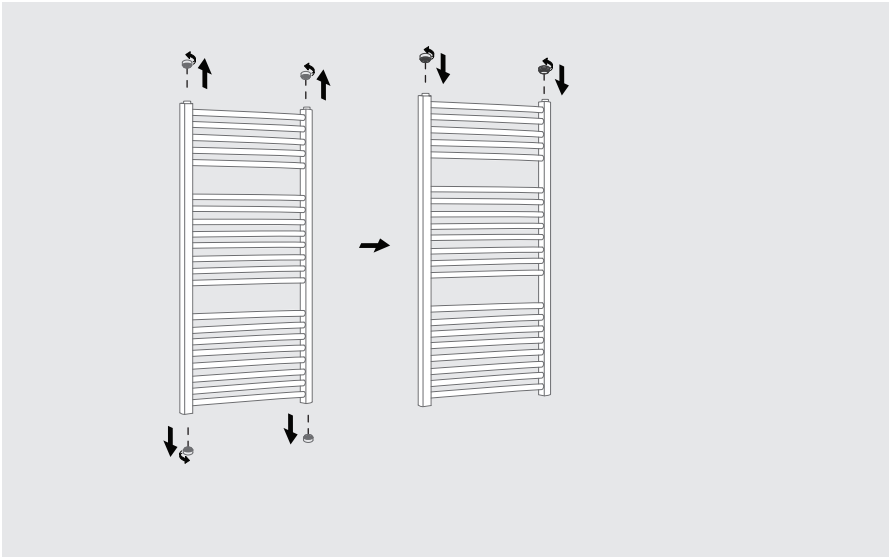

5

Turn the towel rail 180°, Filling the water and anti-freeze fluid with funnel.



Please ignore the following steps if valves to be used.

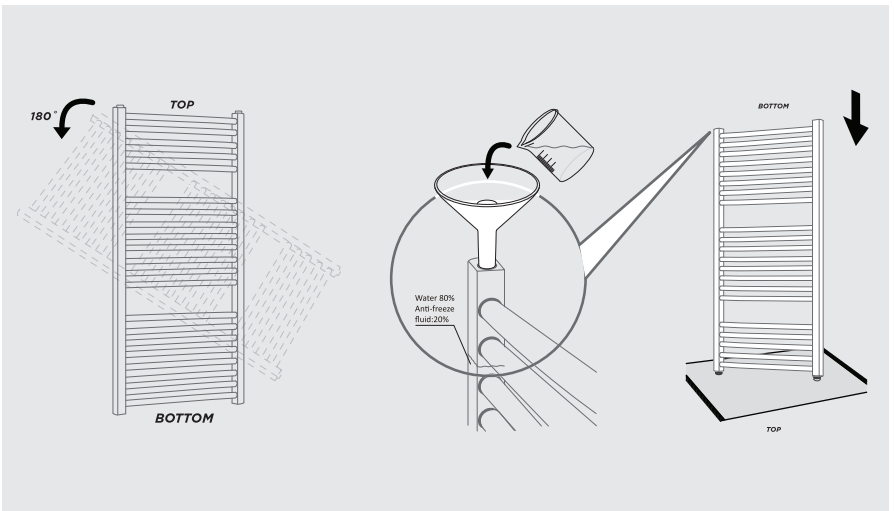

INSTALLATION PROCEDURE

6

Using spanner to switch the blanking plug and heating element onto the threaded hole, connect the heating element and controller.

Option1

Thermostatic
Heating Element



Note: Please make sure the heating element screwed tightly.

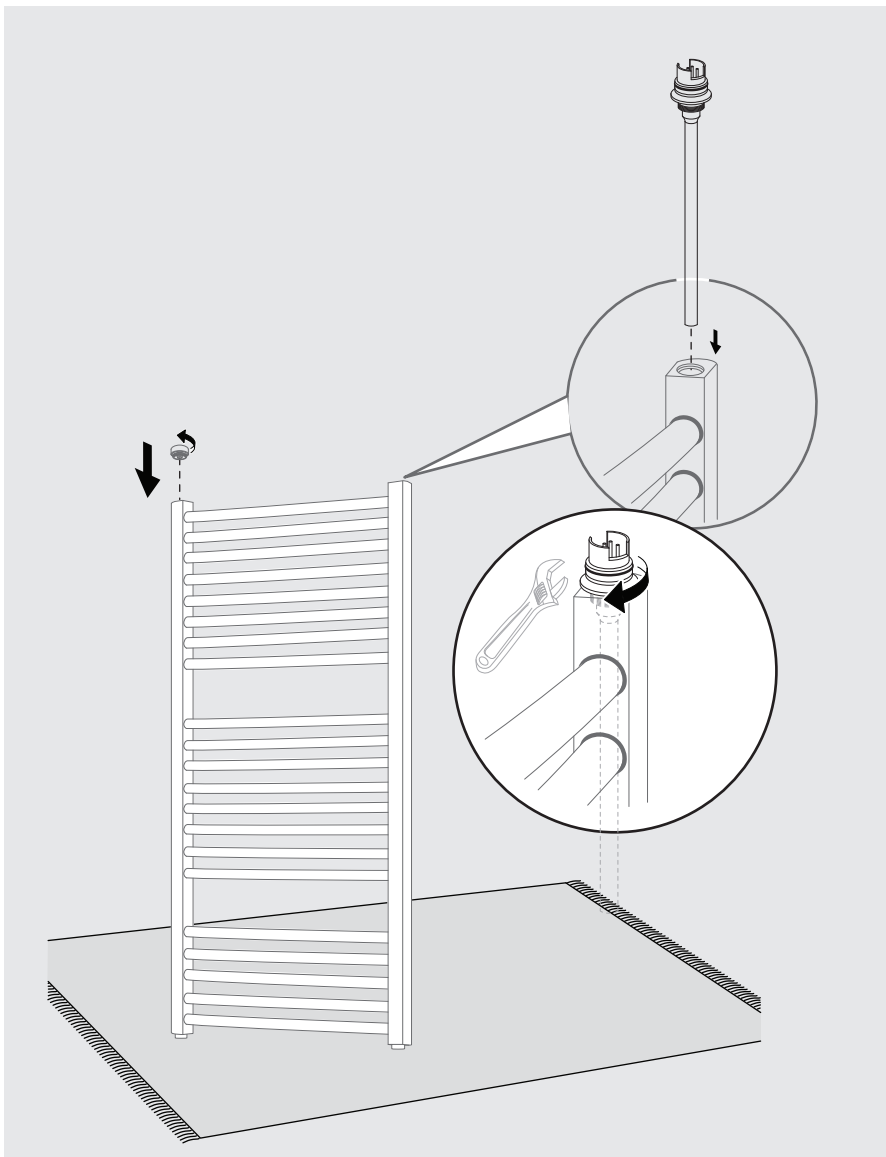

INSTALLATION PROCEDURE

6

Using spanner to switch the blanking plug and heating element onto the threaded hole, connect the heating element and controller.

Option2 Heating Element

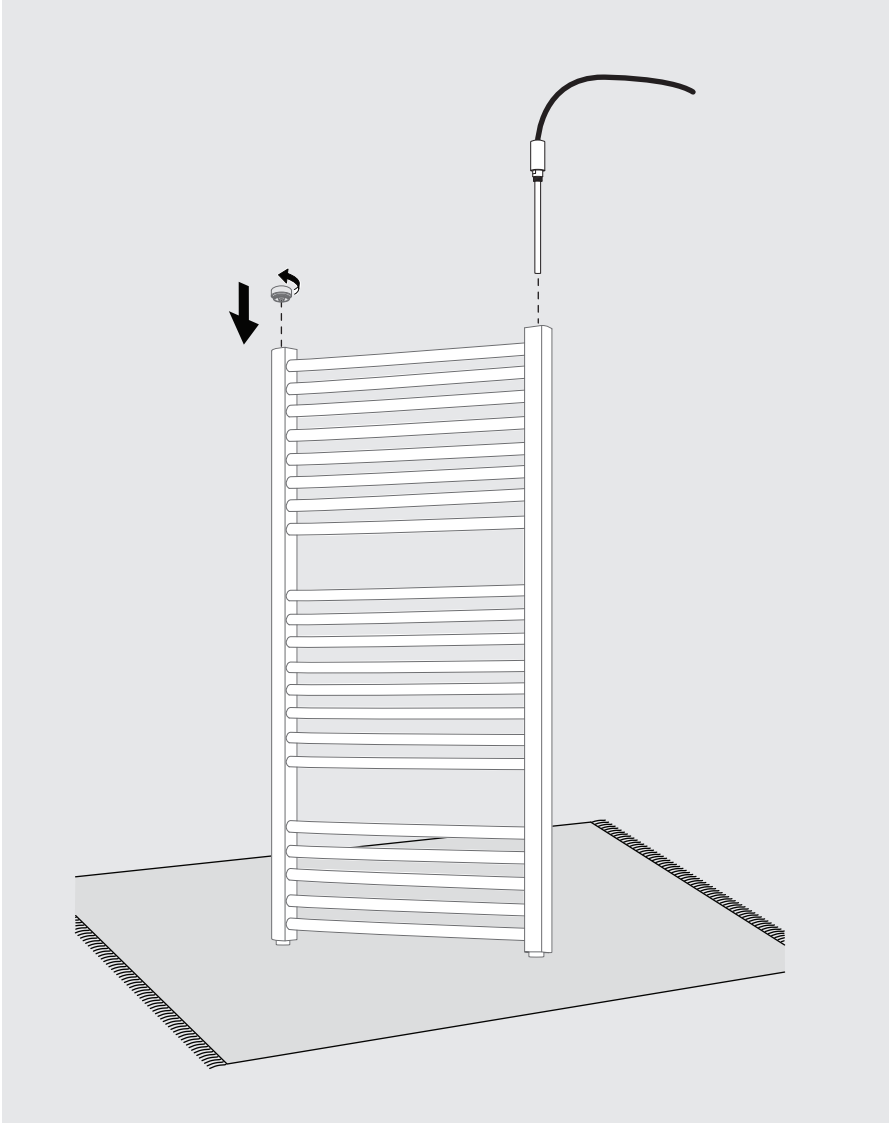

INSTALLATION PROCEDURE

7

Take out the bracket caps, support bracket and screw, put the bracket cap into the gap between horizontal tubes, connect caps and support bracket with screw, adjust the position and tighten the bracket.

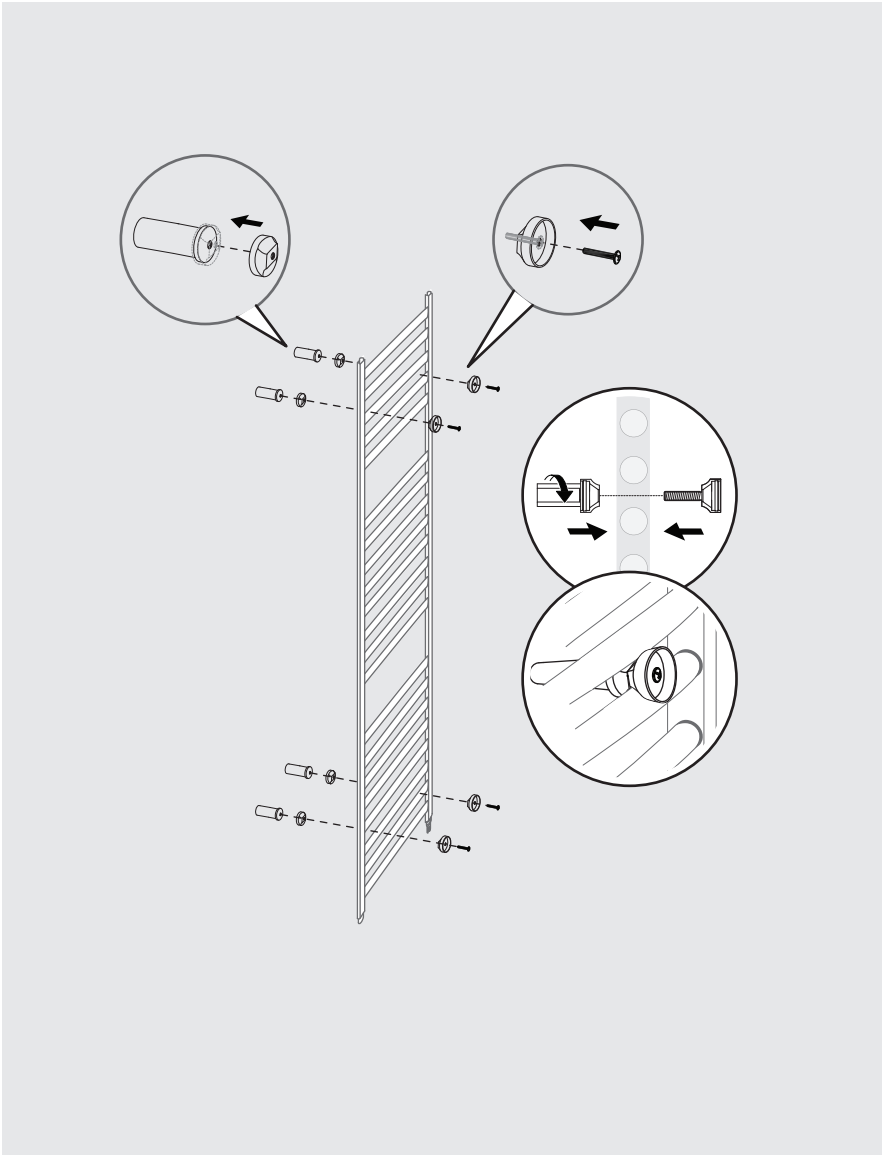

INSTALLATION PROCEDURE

8

Fixing the whole tower warmer onto the wall. Using screwdriver to tighten the screw, connect the support bracket and wall support, and then fix them onto the cover.

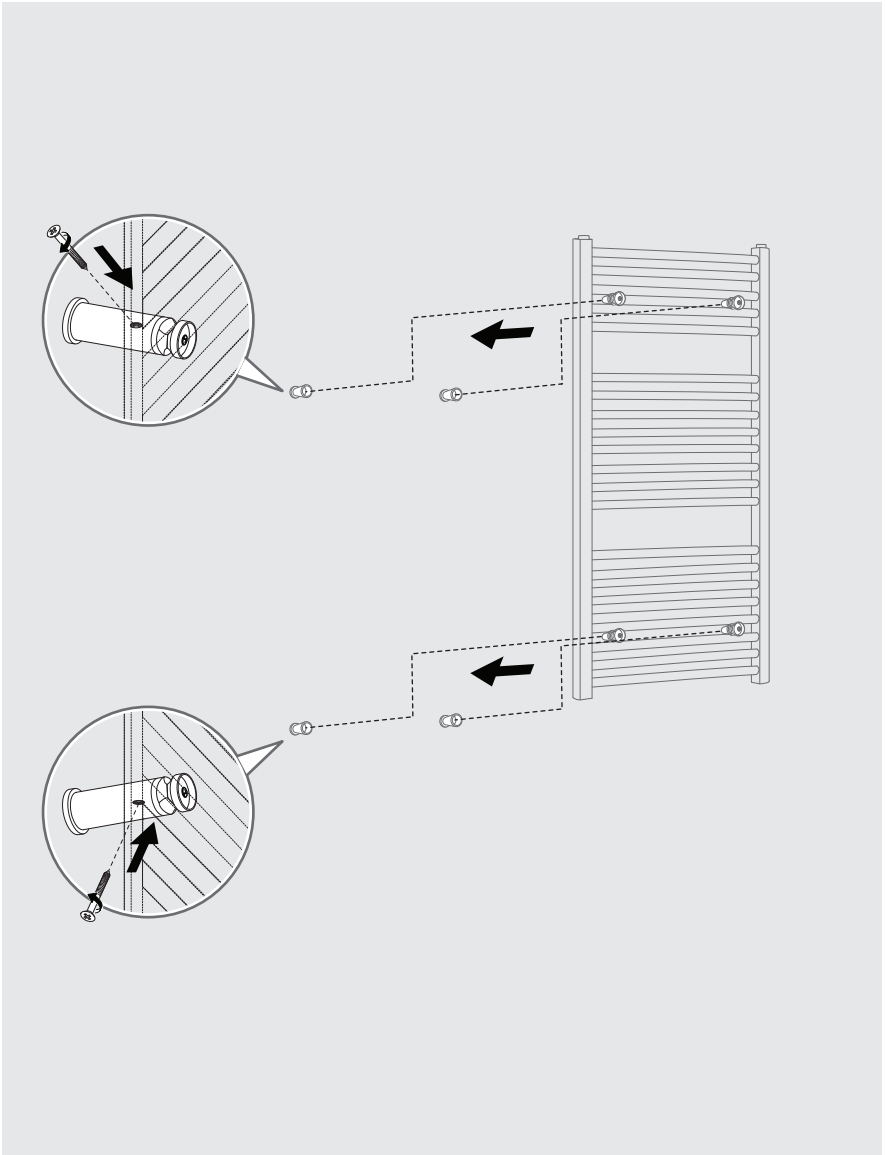

INSTALLATION PROCEDURE

9

Attach the decorative cover to the bracket, and connect the thermostatic unit to the bottom of the heating element.

Option1

Thermostatic Heating Element

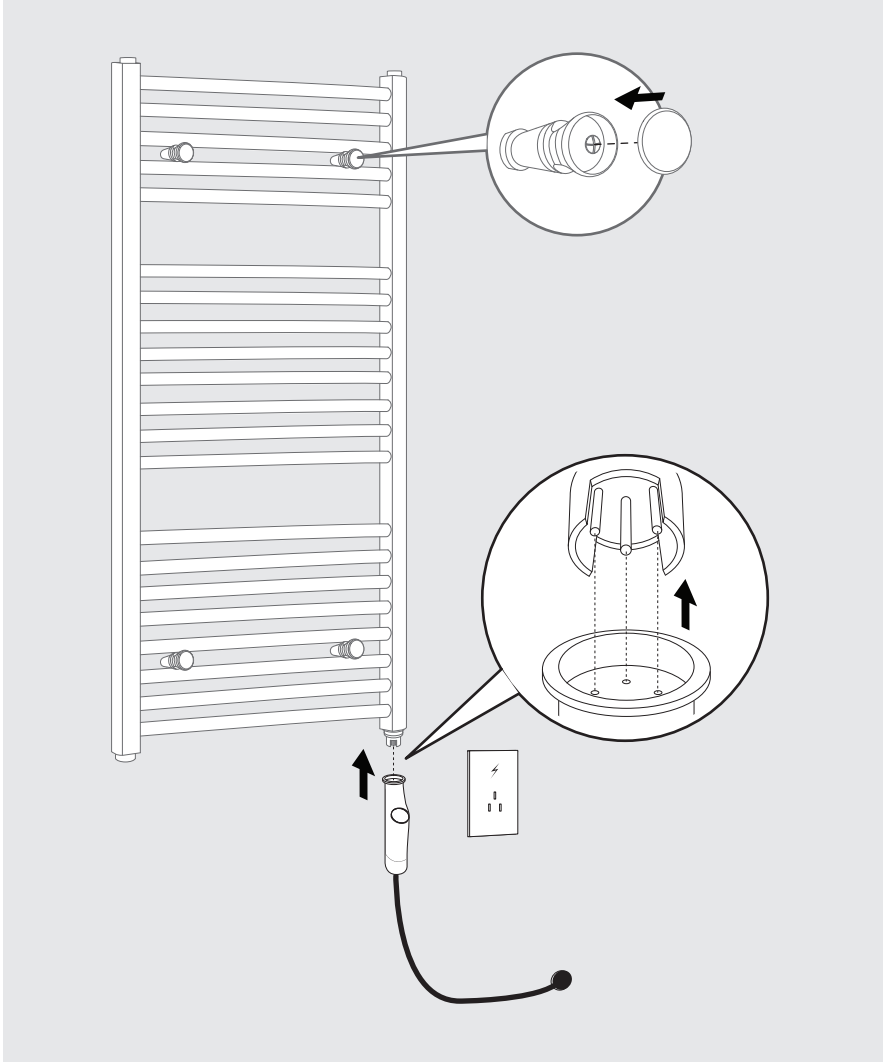

INSTALLATION PROCEDURE

9

Using screwdriver to tighten the screw,connect the support bracket and wall support,and then fix them onto the cover.

Option2 Heating Element

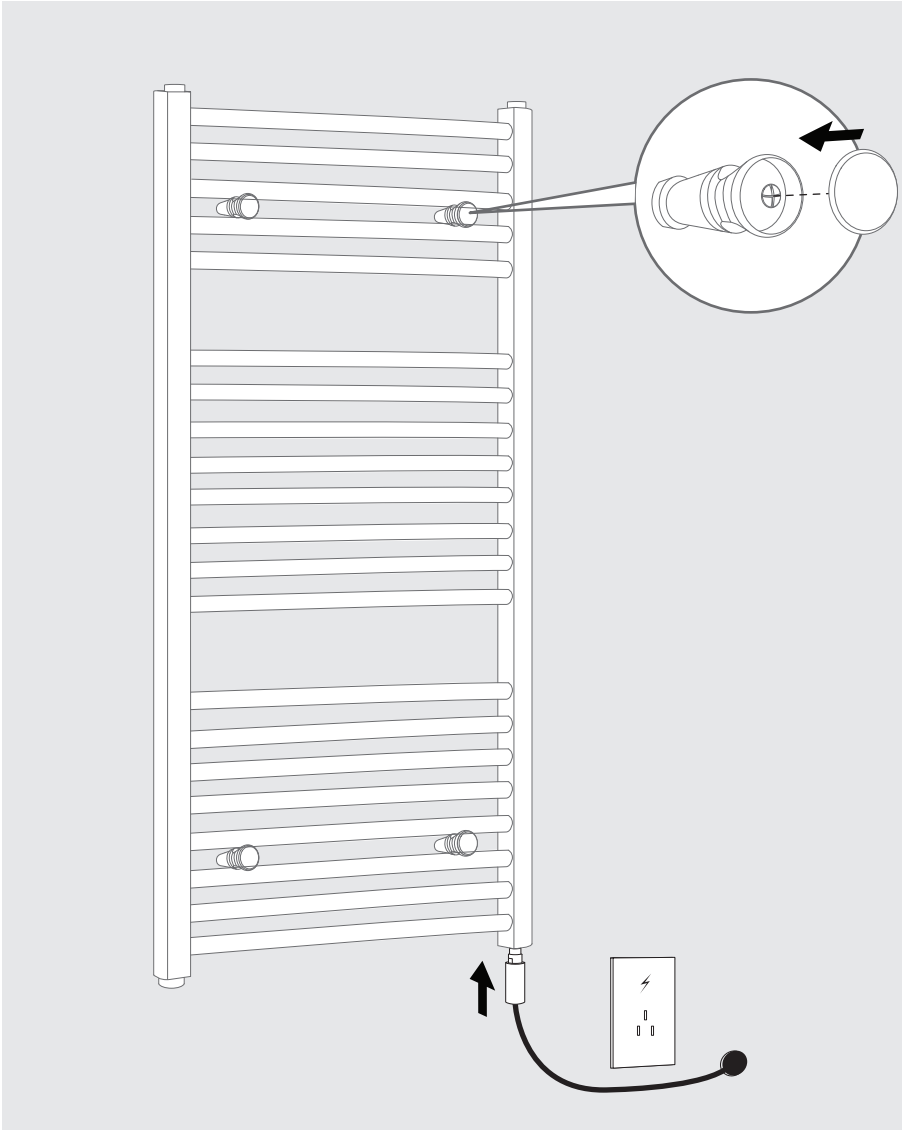

INSTALLATION PROCEDURE

9

Using screwdriver to tighten the screw, connect the support bracket and wall support, and then fix them onto the cover.

Option3

Valve

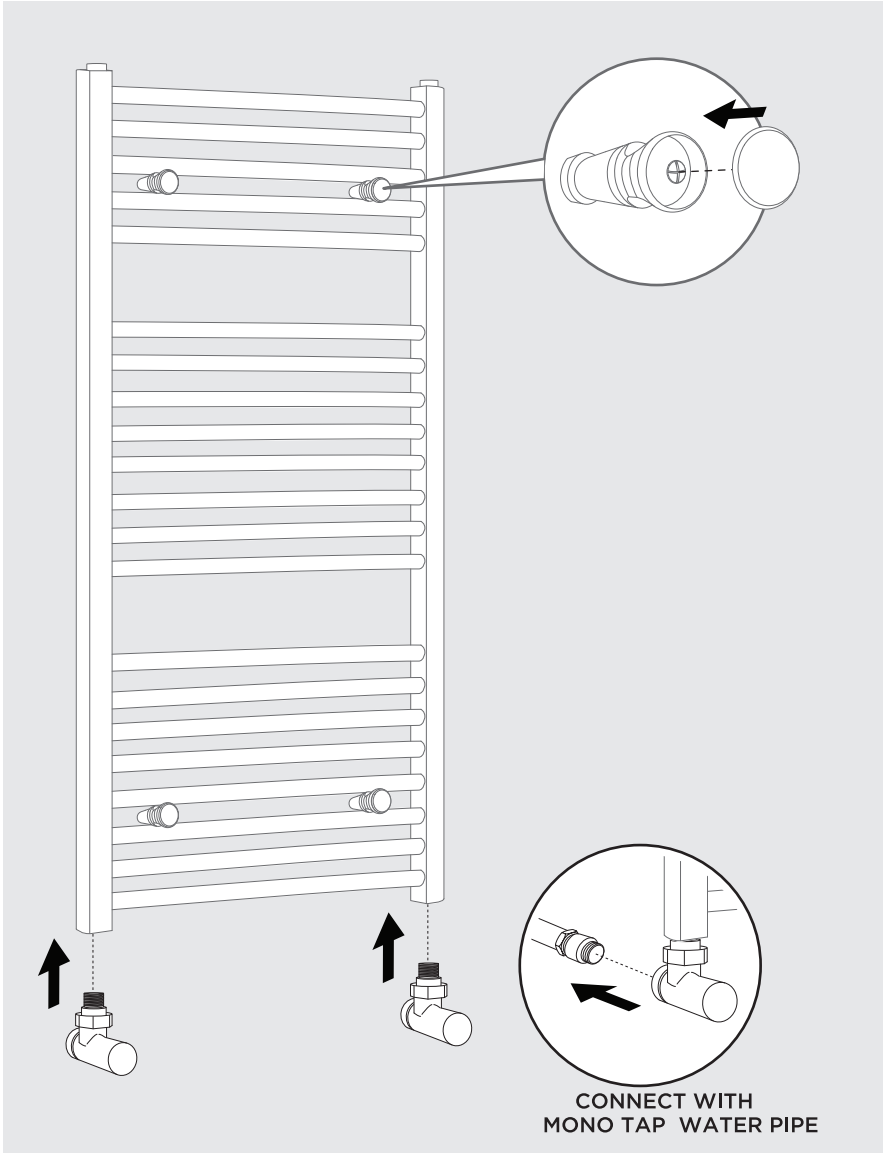

INSTALLATION PROCEDURE

10

Connect valves to household system, turn on water and bleed the radiator to fill with water.

Option1

Thermostatic Heating Element

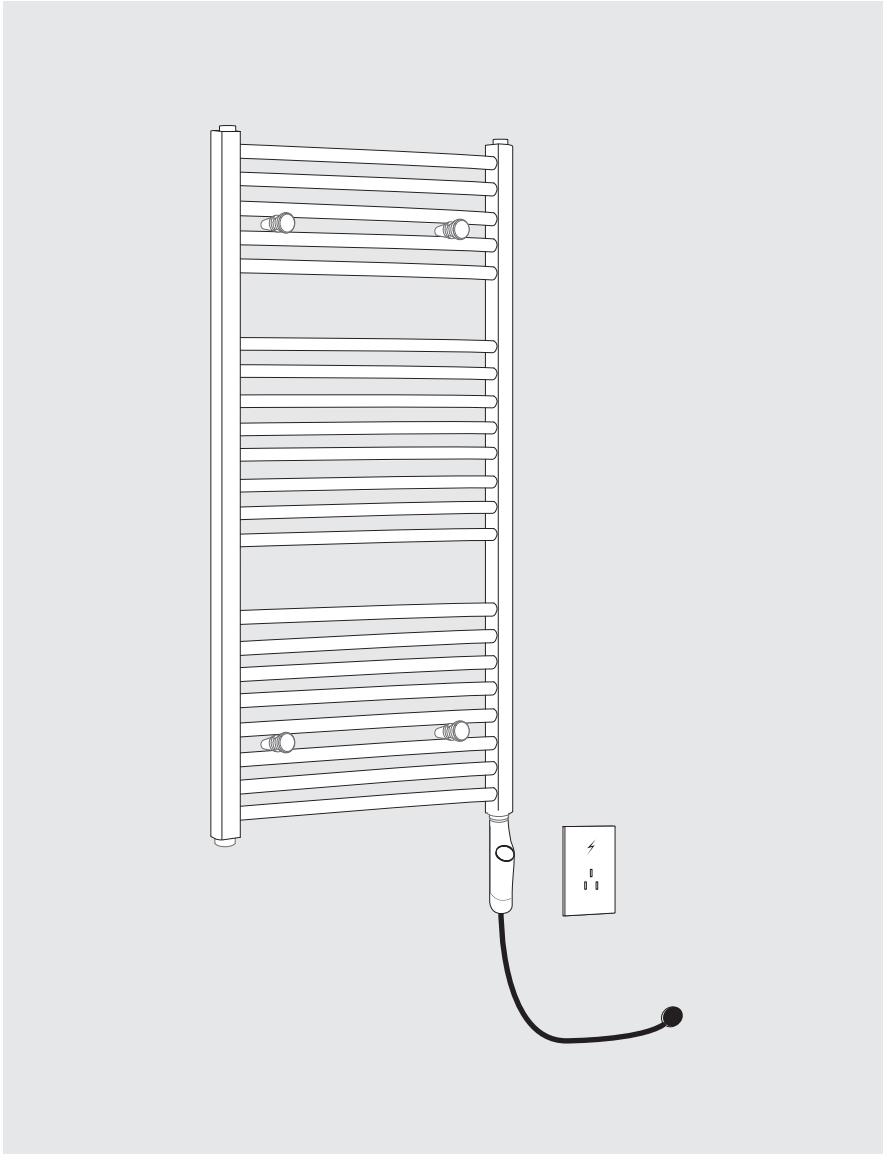

INSTALLATION PROCEDURE

11

Option2 Heating Element

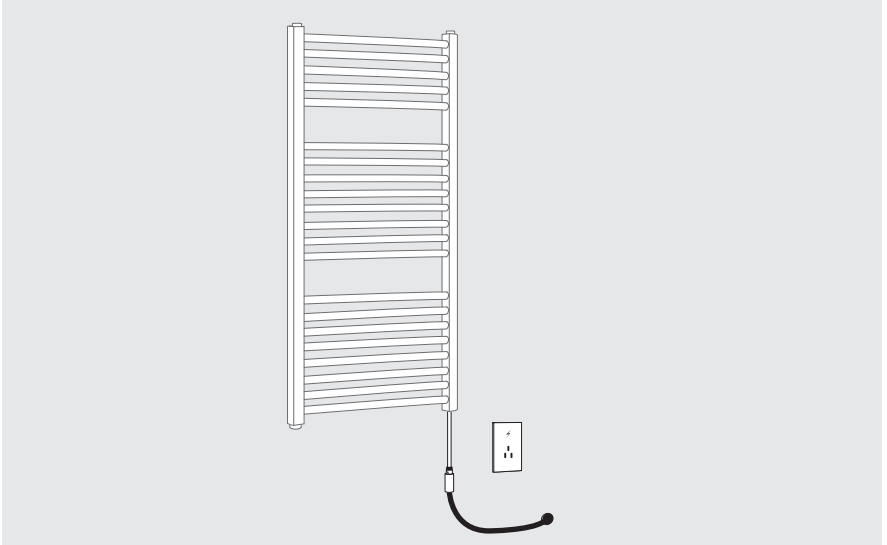

Option3 Valve

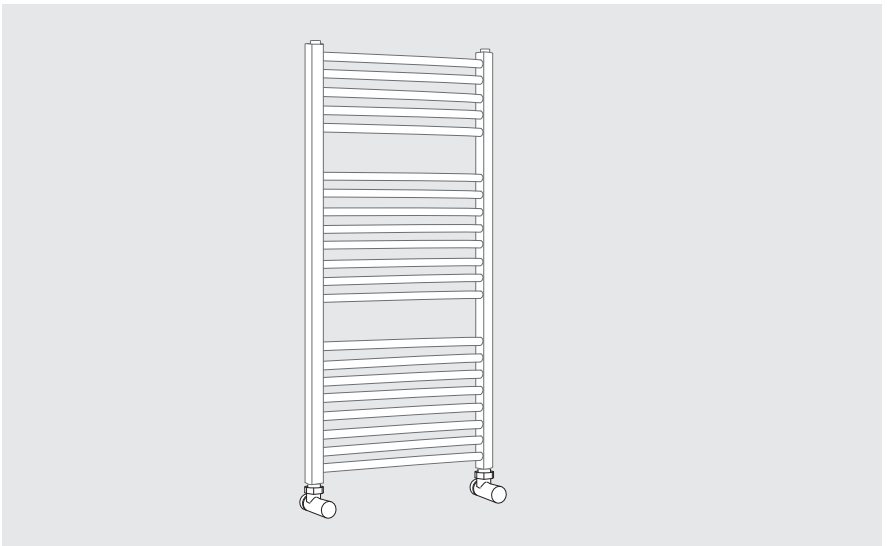

Note: Top up your system with inhibitor fluid after installation

AFTER INSTALLATION

Use a screwdriver to open the air vent,open the valve and let the water rush into radiator.

Check all connection for leaks.

Once water overflows from the air vent,there is no air in the tube.

Use a screwdriver to close the air vent,turn on the valve and the radiator is ready for use.

CARE & CLEANING

Radiators are made from steel and should not be cleaned with corrosive or scouring cleaning agents.

TROUBLE SHOOTING

When your radiator doesn't function, knowing basic radiator troubleshooting can save you from the stress and the hassles of a non-functioning radiator. Here is a guide to solve the most common problems associated with these electric home heaters.

Problem	Cause	Action
Cold spots on the radiator unit	-Water is not flowing through radiator properly	1.Check to make sure there is no trapped air inside the radiator. "Bleed" the radiator to release air. 2.Make sure the valve is fully open to allow water to run freely. Some radiator may need diverter for water to flow properly around the unit.
Leak on the radiator	-Valve nut is loose -Welding problem	-Tighten the valve nut -Replace radiator
Sound of whistling or water whooshing	-Radiator was not properly balanced when it was installed	-Re-install
Clanking sound	-The radiator was installed in a space that doesn't allow for pipe expansion	-Re-install