

# Thermostatic Radiator Valve

## Installation and usage

### Thermostatic head

Connect to the flow (inlet) side of the radiator.

Do not cover and keep free from dust.

Turn handle to reveal the calibration marks denoting the temperature at which the radiator will be turned off.

Turned fully clockwise, the valve operates will be fully shut off. Do not overtighten

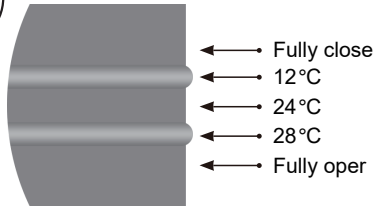
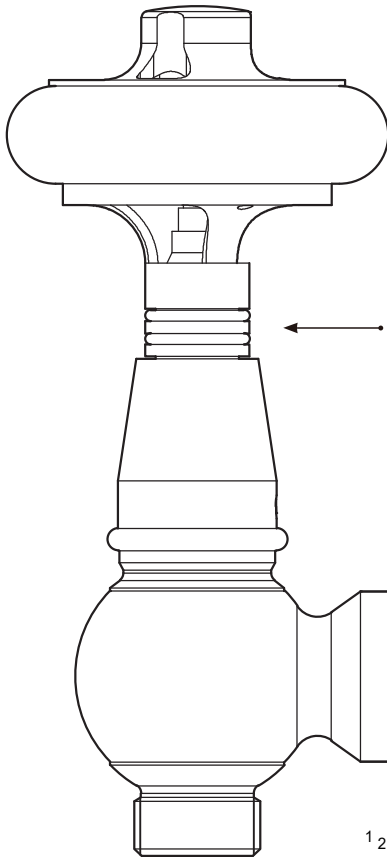

### Technical specifications

Maximum operating pressure: 10 bar

Maximum flow temperature: 110°C

Maximum differential pressure: 1 bar

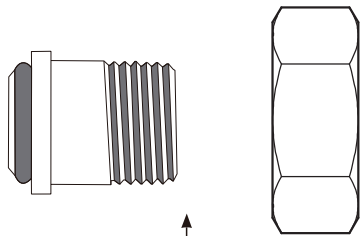

### 1/2" BSP Valve Tail

Screw into the radiator using suitable sealant or tape. Do not overtighten.

### 15mm Compression Fitting

Union with copper pipe.

Tighten the nut onto the olive to form the seal.

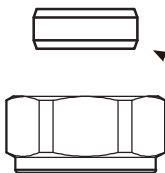

## Lockshield Valve

Connect to the outlet (return) side of the radiator.

Regulates the flow out of the radiator.

Use a key to adjust the flow.

## Balancing the radiators

Always use a qualified plumber to balance the radiators to ensure a uniform temperature throughout the radiator and optimal performance of both the TRV and radiator.

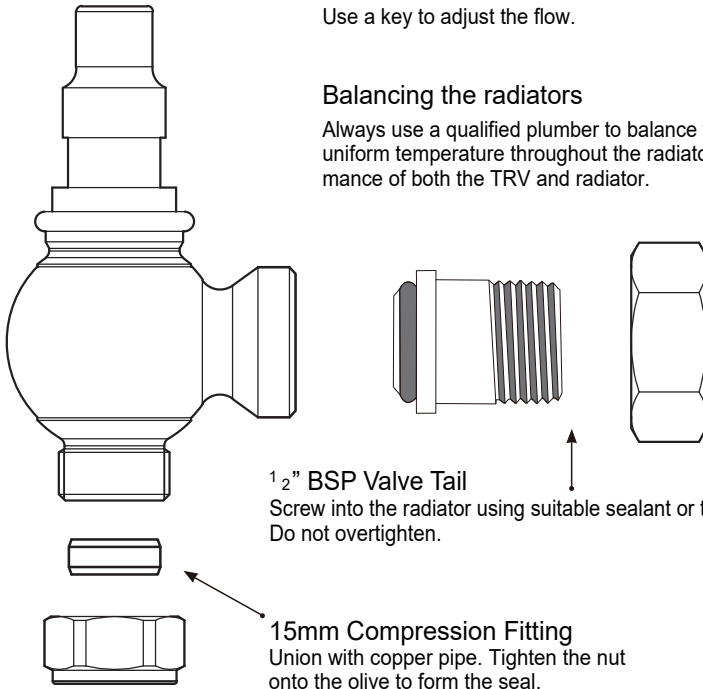

### 1/2" BSP Valve Tail

Screw into the radiator using suitable sealant or tape.  
Do not overtighten.

### 15mm Compression Fitting

Union with copper pipe. Tighten the nut  
onto the olive to form the seal.

## Connection

Windsor valves are unidirectional. The TRV should be connected to the flow and the lockshield to the return side of the radiator.

## Cleaning

Abrasive and solvent cleaners should not be used when cleaning the valves to avoid the risk of scratching the decorative surface.

## Radiator removal

To remove the radiator, the valve must be fully shut off by turning fully clockwise

## Summer operation

If the heating system is to be out of use for a period of months it is recommended that all TRVs are opened fully to allow free movement of water within the system.